

HOW TO PLAY

CRAPS

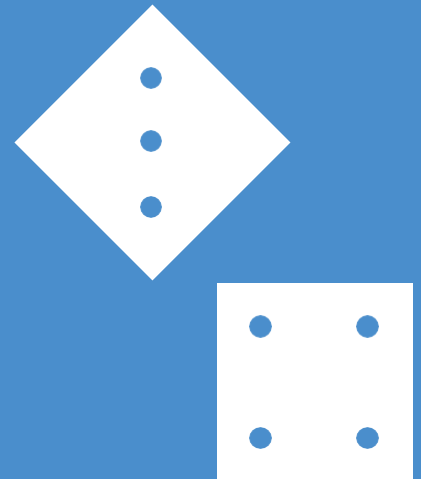

Dice games have been popular for thousands of years. There's nothing quite as simple or unpredictable as the roll of the dice. This unique combination makes Craps one of the most accessible and suspenseful games in the casino. To make the most of the game, the Craps table presents a wide variety of betting options – making this simple game diverse, fast paced and fun-filled.

SETTING YOUR SIGHTS FOR SHOOTING CRAPS

Craps is played on a long table (see diagram) using two dice that are numbered from 1 to 6. The combined value of the two dice can therefore total anywhere between 2 and 12. However, certain numbers are more likely to come up more often. For instance, you only have one chance of throwing a 2 (1/1) or 12 (6/6); yet you have five chances of throwing an 8 (2/6, 3/5, 4/4, 5/3, 6/2). And this is the essence of Craps.

The dice are rolled from where the Player is standing to the end that is furthest from the person, where they should hit the opposite end of the table.

Each toss of the dice is called a "roll", and each Player receives a turn. Should the previous Shooter roll a 7-out, the next Player in turn is offered the dice progressing clockwise around the table.

THE AIM OF THE GAME

The Player rolling the dice is known as the "Shooter" and their first roll is known as the "come out roll". The Shooter betting on the Win Line wins if the total is 7 or 11 on the come out roll, but loses if the total is 2, 3 or 12. Any other number thrown on the come out roll becomes the "point". In this case,

the Shooter continues to roll the dice until the point number is rolled again, before rolling a 7. If the Shooter rolls the point, the Shooter wins, if a 7 is rolled before the point the Shooter "sevens out" and loses, and the game restarts with the next Shooter in line. For the Shooter betting on the don't win line the opposite applies with the exception that a total of 2 on the come out roll is a standoff. Same rules apply for Shooter and Player.

A black and white "puck" is used to mark the point number on the table. A winning Shooter continues to roll the dice; a losing Shooter surrenders the dice to the next Player.

The aim of the game is initially to bet either with or against the Shooter. However, once the point has been established, a whole range of betting opportunities is opened up. The wide range of bets in Craps can make the game seem tricky at first. But remember, there's nothing quite as simple as the roll of the dice.

THE RANGE OF BETS IN CRAPS

The Craps table has varying minimum and maximum bets. Please check the sign displaying the minimum and maximum bets at the table.

CAN YOU GUESS HOW THE TWO DICE WILL FALL?

Come along to the Craps table and try your luck at the most suspenseful of casino games. Our helpful gaming team will be happy to answer any questions you may have.

THE MANY POSSIBILITIES OF THE CRAPS TABLE

A WIN LINE: PAYS EVEN MONEY

The basic bet in Craps is a wager placed on the "win line". This bet must be placed before the Shooter's come out roll. If the initial roll totals 7 or 11, bets placed on the win line will be paid immediately. If 2, 3 or 12 is rolled, bets placed on the win line are lost. Any other number rolled becomes the point. If the Shooter rolls the point again without rolling a 7, you win. Should a 7 come up, you lose. A win line bet may not be removed or reduced once the point has been established.

B DON'T WIN: PAYS EVEN MONEY

Alternatively, you may bet against the dice on the "don't win". This is the reverse of the win line bet, and must also be placed before the Shooter's come out roll. Here you lose if 7 or 11 is rolled, and win on 3 or 12. A roll of 2 becomes a "stand off" – you neither win nor lose. Any other number rolled becomes the point. If the Shooter rolls the point again without rolling a 7, you lose. Should a 7 come up, you win. A don't win bet may be reduced or removed at any time, but not increased or replaced until the next come out roll.

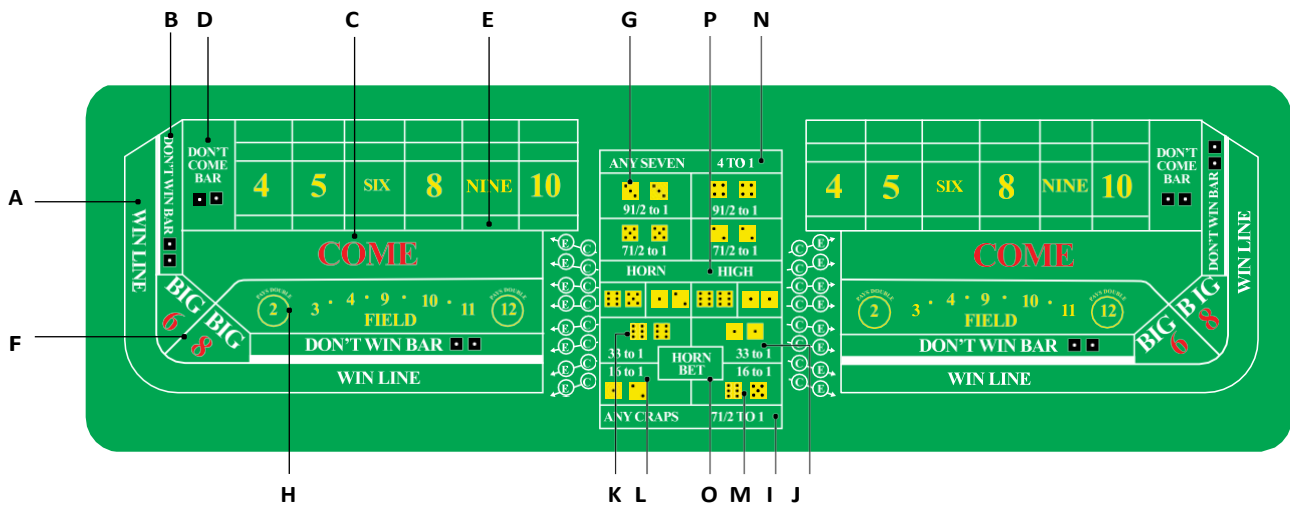

C COME: PAYS EVEN MONEY

"Come" bets are similar to win line bets. Come bets are made after the point has been established. Again you win on 7 or 11, and lose on 2, 3 or 12. And again any other number rolled becomes your come point. The come point must be rolled again without rolling a 7 for you to win. Should a 7 come up, you lose. A come bet may not be reduced or removed.

D DON'T COME: PAYS EVEN MONEY

"Don't come" bets are similar to don't win bets. Don't come bets are also made after the point has been established. Again you lose on 7 or 11, and win on 3 or 12, with 2 being a stand off. And again any other number rolled becomes your don't come point. If the Shooter rolls your don't come point again without rolling a 7, you lose. Should a 7 come up, you win. A don't come bet may be reduced or removed at any time, but may not be replaced or increased after the removal or reduction.

E PLACE – TO WIN

"Place" bets may be made on any individual point number. Your bet wins if your number comes up before a 7 is rolled but not on a come out roll, unless you request your place bets working. Your place bet may be increased, decreased or removed at any time.

PAYS 9 TO 5 ON 4 OR 10
PAYS 7 TO 5 ON 5 OR 9
PAYS 7 TO 6 ON 6 OR 8

F BIG 6 OR BIG 8

Wins if a 6 or 8 is rolled, Loses if a 7 is rolled, PAYS EVEN MONEY - Works every roll.

G HARD WAYS

"Hard ways" bets are made on any of the even point numbers (4, 6, 8, 10) being rolled the "hard way" – that is, as pairs: 2/2, 3/3, 4/4, 5/5 – or before a 7 or an even point number is rolled any other way. Bets may be placed on any of the hard way numbers on any roll of the dice but will not work on the come out roll, unless requested.

PAYS 7.5 TO 1 ON HARD WAYS 4 OR 10
PAYS 9.5 TO 1 ON HARD WAYS 6 OR 8

ONE ROLL BETS

The following "one roll" bets may be made on any roll of the dice.

H FIELD

Your "field" bet wins if 2, 3, 4, 9, 10, 11 or 12 is rolled and loses on any other number.

PAYS EVEN MONEY ON 3, 4, 9, 10 AND 11
PAYS 2 TO 1 ON 2 AND 12

I ANY CRAPS: PAYS 7.5 TO 1

Your "any Craps" bet wins if 2, 3 or 12 is rolled and loses on any other number.

J CRAPS 2: PAYS 33 TO 1

Your "Craps 2" bet wins on a throw of 2 only and loses on all other numbers.

K CRAPS 12: PAYS 33 TO 1

Your "Craps 12" bet wins on a throw of 12 only and loses on all other numbers.

L CRAPS 3: PAYS 16 TO 1

Your "Craps 3" bet wins on a throw of 3 only and loses on all other numbers.

M ELEVEN: PAYS 16 TO 1

Your "eleven" bet wins on a throw of 11 only and loses on all other numbers.

N ANY 7: PAYS 4 TO 1

Your "any 7" bet wins on a throw of 7 only and loses on all other numbers.

O HORN

Your "horn" bet must be made up of equal wagers placed on each of the four numbers 2, 3, 11 and 12. Your total bet should therefore be divisible by four. For example, you could place \$5 bets on each of the four numbers, making a total horn bet of \$20. You win if 2, 3, 11 or 12 is rolled, and lose on any other number. Pays the appropriate odds based on the number rolled.

P HORN HIGH

Like the horn bet, your "horn high" bet wins if 2, 3, 11 or 12 is rolled and loses on any other number. The difference here is that the horn high bet must be made up of equal wagers placed on any three of the numbers and a double wager placed on the remaining number. The total bet should therefore be divisible by five. For example, you could place \$5 bets on 2, 3 and 12 and a \$10 bet (double your other bets) on 11, making a total horn high 11 bet of \$25. Pays the appropriate odds based on the number rolled.

THE ODDS OF WINNING

Craps is a game played with 2 dice where Players may wager on any combination of the 2 dice. There are a wide range of bets on Craps which may seem tricky at first, but taken individually, the bets are quite simple. Players are given the chance to roll the dice provided they have a wager on the win line or don't win line. As 7 is the most common combination, many of the wagers are based on the Shooter rolling a 7 or not rolling a 7. An example of this is 8 the hard way (4/4) wins, if the Shooter rolls two 4s and only loses, if the Shooter rolls a total of 7 or another combination of 8. One roll wagers are wagers that are determined on the outcome of the next roll – for example, the field is a series of dice totals (2, 3, 4, 9, 10, 11 and 12) that win if any of the totals are rolled and lose if any other total is thrown. The overall Craps House edge is approximately 2%. Craps has a variety of house edges from a one roll wager on "Any 7" (16.67%) to a "Win Line" wager (1.41%), after which the player can place an optional supplementary Win Line "Odds" bet that has a zero-house edge (0%).

RESPONSIBLE GAMBLING

The casinos promote a responsible approach to gambling and offer gambling for your enjoyment. Only you can decide how much time and money you want to spend on gambling at a casino. If you think you may have a problem controlling your gambling behaviour, please contact:

Gambling Helpline 1800 858 858
gamblinghelponline.org.au

Gambling Help services are independently run and offer free, confidential support (available 24 hours).

Bet with your head, not over it.